

COUNTERWEIGHT EASEL INSTRUCTIONS (page 1 of 3)

Hardware List

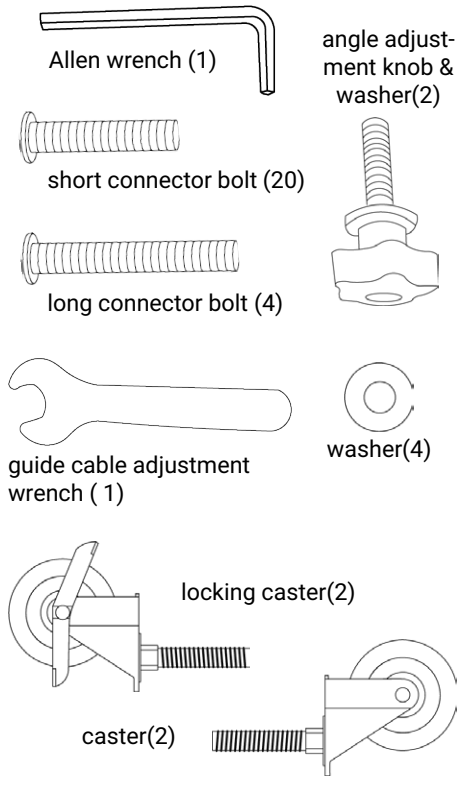

angle adjustment knob & washer(2)

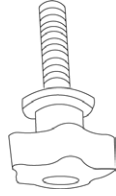

Parts List

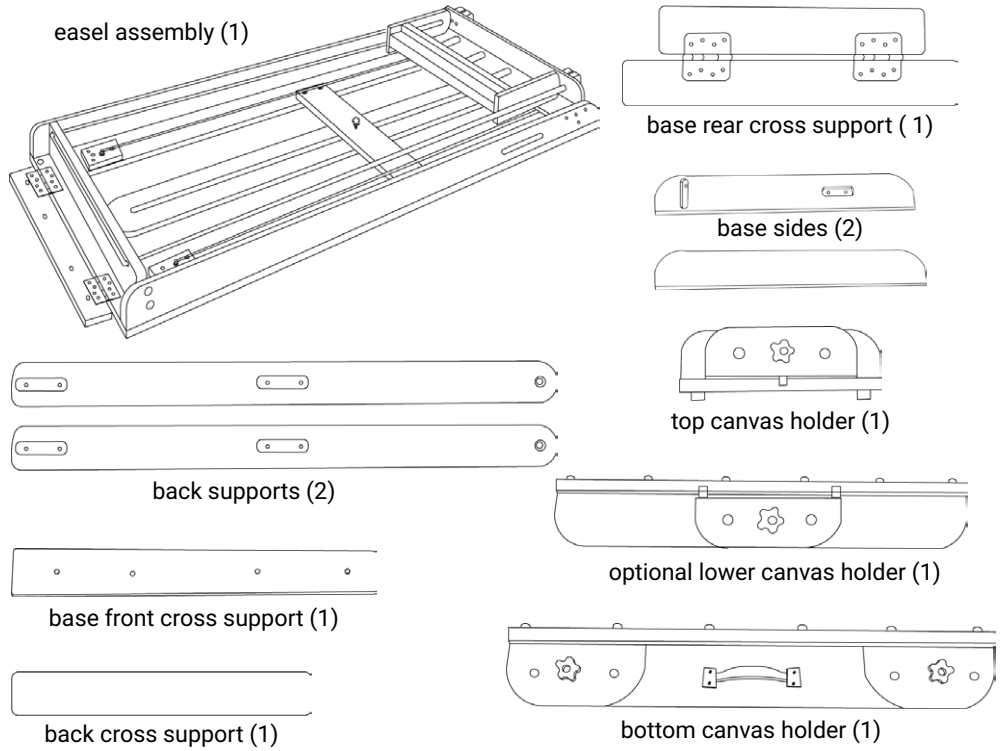

Assembly Instructions

- 1 Assemble the base base sides, base front cross support, base rear support using 8 short connector bolts.
NOTE: Make sure the rear cross support hinges face inward (toward the front of easel).

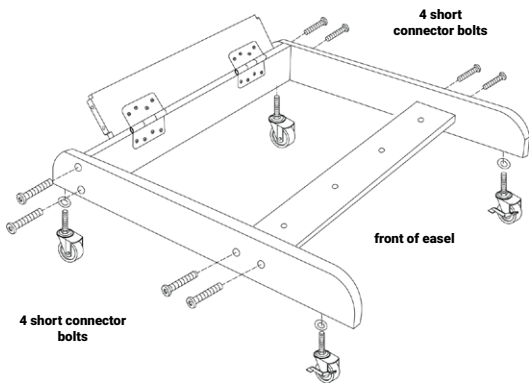

- 2 Insert metal washer to the bolt of caster. Attach caster with lock to front and caster to rear.

- 3 Attach easel assembly to front cross support using 4 short connector bolts.

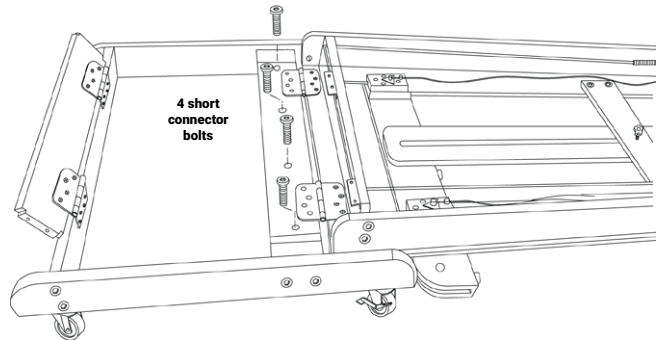

- 4 Attach the back supports and back cross support to the base with 8 short connector bolts.

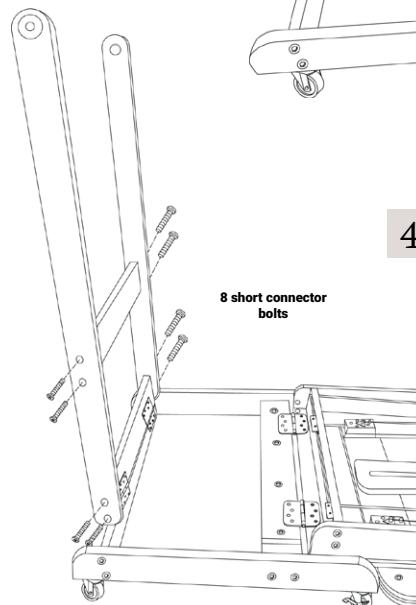

continued instruction on reverse →

Assembly Instructions continued

- 5** Raise the easel assembly and connect back supports with 2 angle adjustment knobs.

The back support fits inside easel assembly. The knobs thread into the back supports through the angle adjustment slots.

NOTE: This step is much easier with two people.

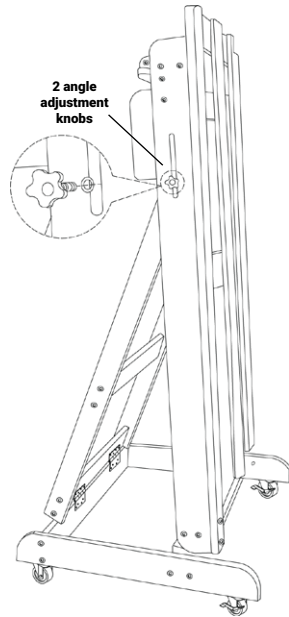

Make sure the smooth side (rounded edge) of the washer faces the wood.

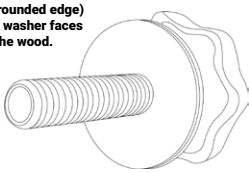

- 5** Attach the bottom canvas holder using 4 long connector bolts. Make sure the round clamping disks are in place.

NOTE: It will be necessary to bend the wire to the side to insert 2 of the bolts. Leaving the weight box empty makes this easier.

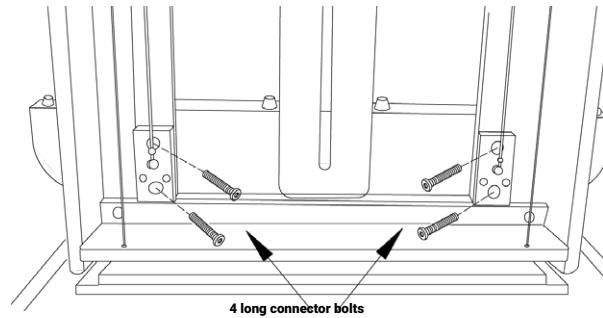

- 6** Attach the top canvas holder and optional lower canvas holder.

Slide canvas holder onto center mast.

TIP: the canvas holder guide blocks can be adjusted slightly by loosening and tightening the guide block bolts.

TIP: The optional lower canvas holder is useful for holding smaller paintings. It also features clips for holding panels.

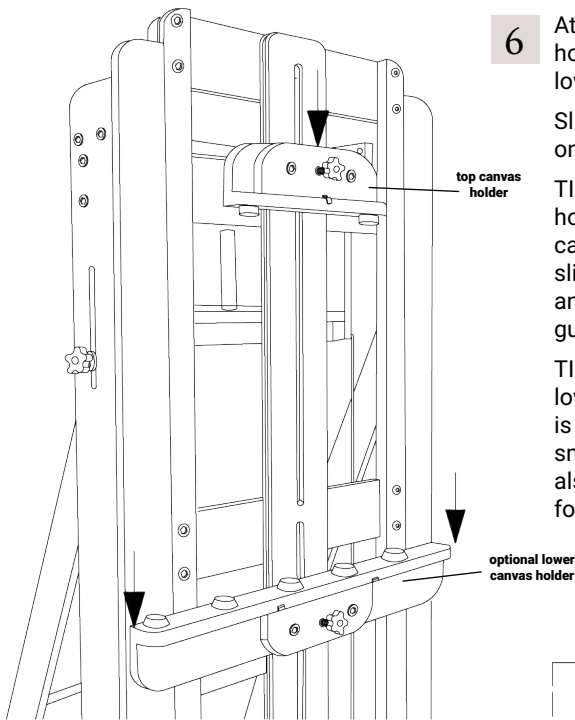

additional 2-1/2 weight plate to balance optional lower canvas holder (add more as needed)

four 5lb weight plates to balance easel

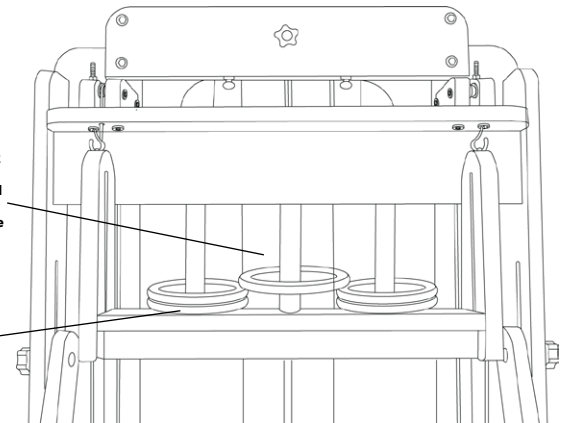

- 7** Add weights to the weight box.

TIP: First lock the sliding carriage in place with the 2 locking knobs on the bottom canvas holder.

NOTE: Weights are not included with the easel to avoid excessive shipping costs.

The easel uses standard 2-1/2 and 5 pound weight plates. These can be purchased at any sports equipment store.

Four 5 pound weight plates are required to balance the easel (without the optional lower canvas holder).

Use an additional 2-1/2 pound weight plate to balance the easel with the optional lower canvas holder. Add additional 2-1/2 pound weight plates as needed depending on the size and weight of your paintings.

- 8** It may be necessary to occasionally tighten the guide cables for the weight box.

Hold the brass eye hooks while tightening the nut with the included wrench.

NOTE: Do not over tighten the guide cables. They should be slightly taut, not very loose or very taut.

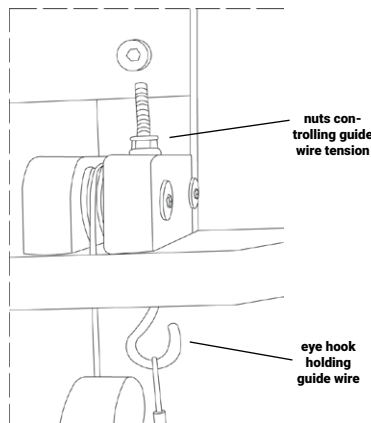

COUNTERWEIGHT EASEL

OPERATING INSTRUCTIONS (page 3 of 3)

The Sienna Studio Counterweight easel is versatile, easy to adjust and user-friendly. It features a counterweight system to raise and lower your paintings with a lift of the handle.

1 To raise and lower the carriage.

- Loosen clamping knobs on the bottom canvas holder.
- Raise or lower carriage to desired height.
- Tighten clamping knobs.

2 Adjusting tilt of easel.

- Stand in front of easel.
- Loosen angle adjustment knobs.
- Adjust easel to desired angle, tighten knobs.

3 Raise center mast.

- Tighten clamping knobs on the bottom canvas holder.
- Loosen 2 mast adjustment knobs.
- Raise mast to desired height and tighten knobs.

4 Adjusting the top canvas holder and optional lower canvas holder.

- Tighten clamping knobs on the bottom canvas holder.
- Loosen clamping knob on canvas holder.
- Adjust canvas holder to desired height and tighten clamping knob.
- NOTE: the top canvas holder and optional lower canvas holder have panel clips for holding thin painting panels.

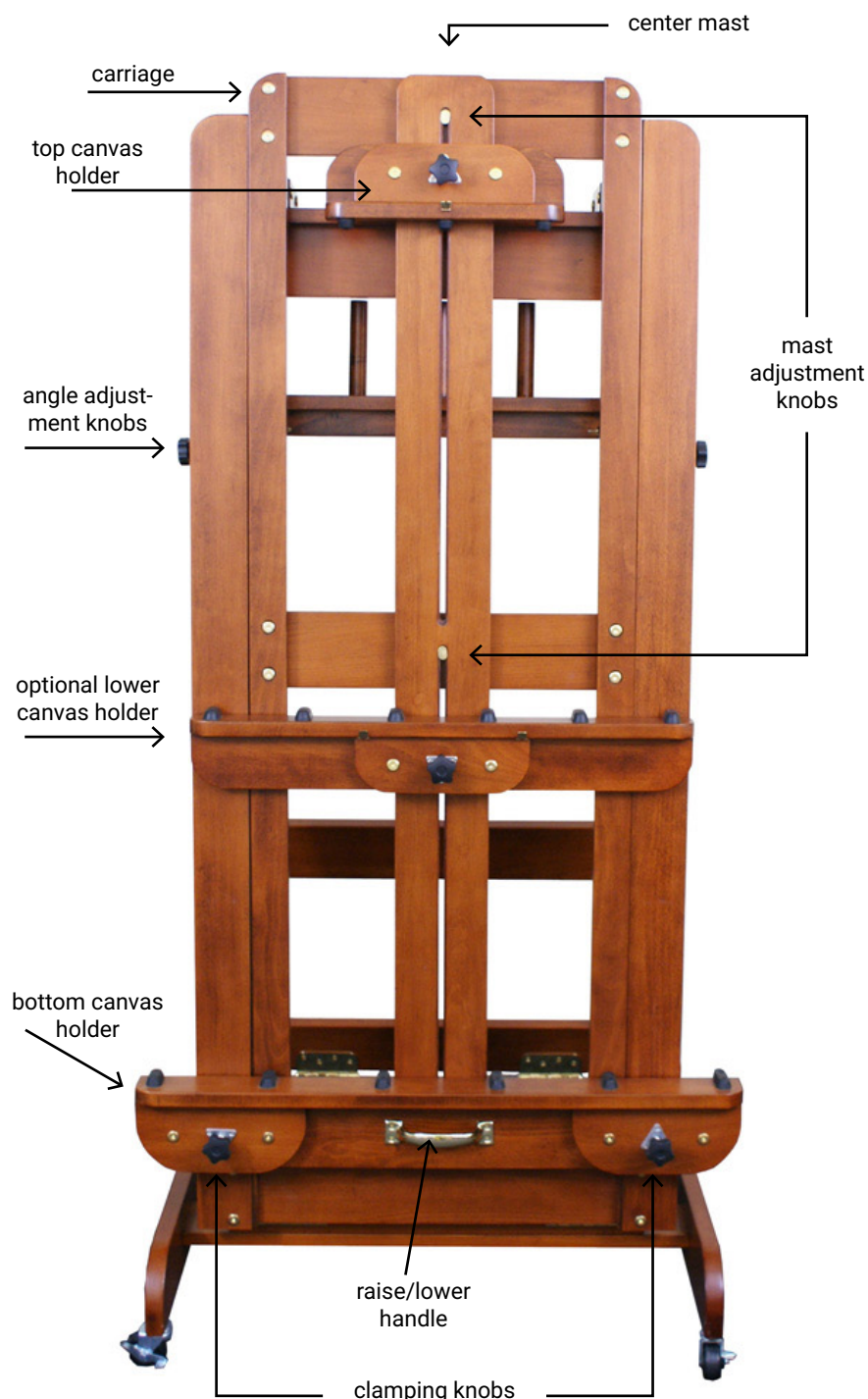

sienna
plein air

Jack Richeson & Co., Inc.
557 Marcella St. Kimberly, WI 54136

1.800.233.2404
richesonart.com  